

LOCKER CH 2 BW

- | | | |
|---|-----|-------------------------|
| 1 | SK | Montážny návod |
| 2 | CZ | Montážní návod |
| 3 | DE | Montageanleitung |
| 4 | ENG | Assembly instructions |
| 5 | PL | Instrukcja montażu |
| 6 | RO | Instrucțiuni de montaj |
| 7 | IT | Istruzioni di montaggio |

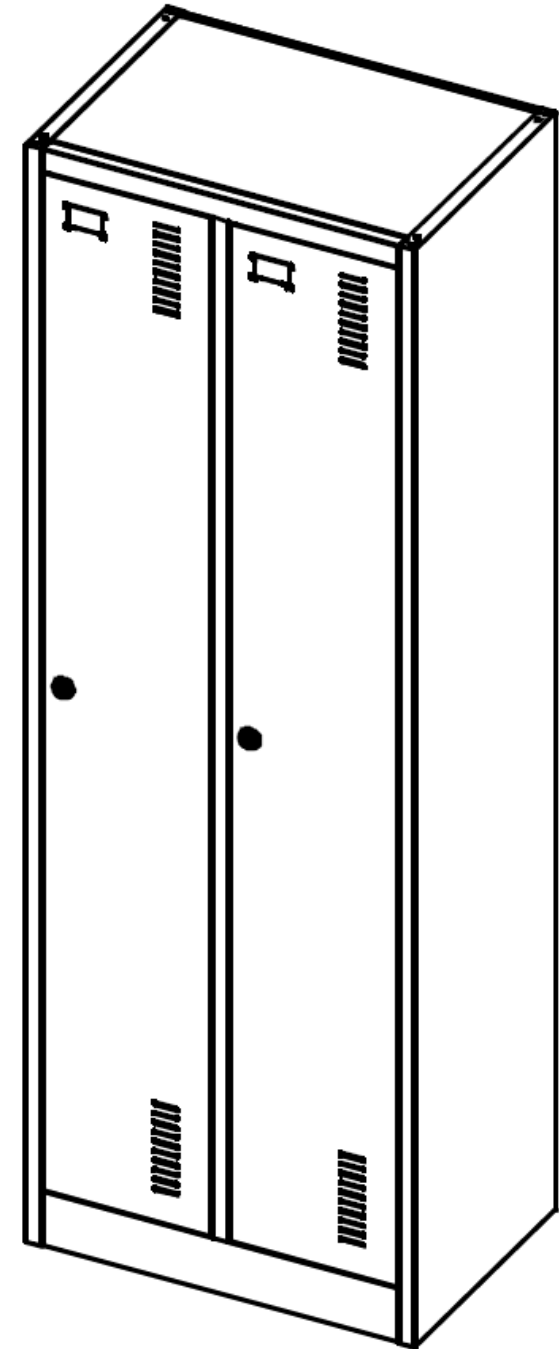

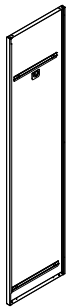

Ľavá strana: 1 ks



Pravá strana: 1 ks

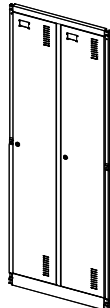

Rám dverí: 1 ks

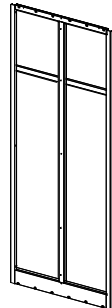

Zadná doska: 1 ks



Deliaca doska: 1 ks



Deliaca doska: 2 ks

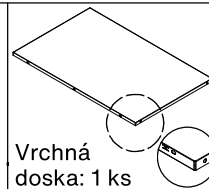

Vrchná doska: 1 ks

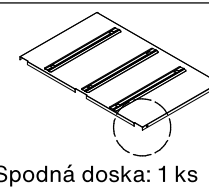

Spodná doska: 1 ks

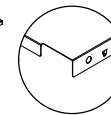

Malé police:
Ľavá (malá): 1 ks
Pravá (veľká): 1 ks



Samorezné skrutky (5x10): 19 ks



Kľúče: 2 sety



Háčiky: 8 ks

Vešiaková tyč:
Krátka: 1 ks
Dlhá: 1 ks
Stredná: 2 ks

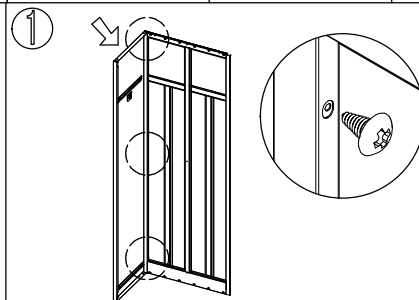
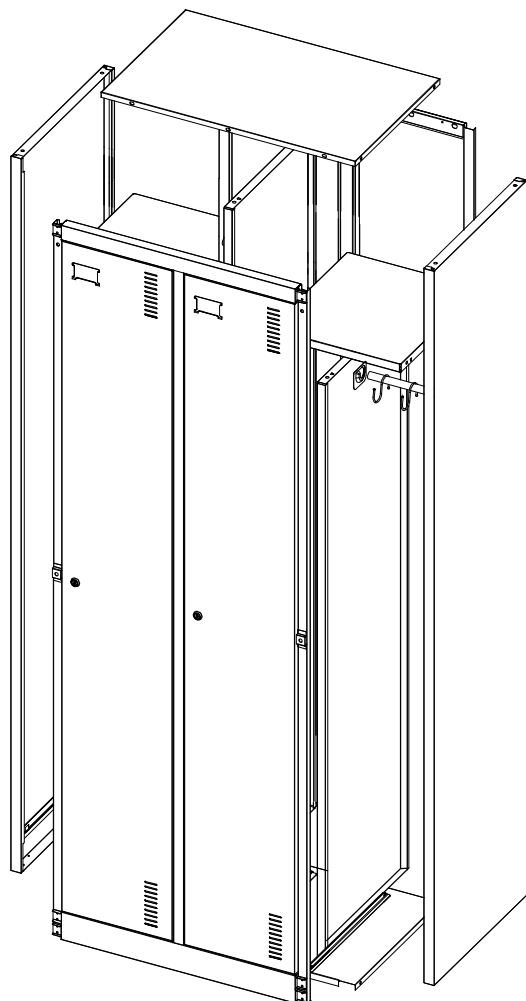
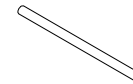

1 Priskrutkujte ľavú stranu a zadnú dosku samoreznými skrutkami (5x10).

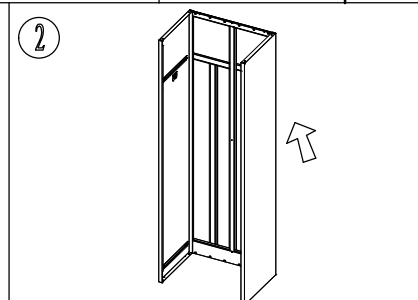

2 Pravú stranu priskrutkujte k zadnej doske rovnakým spôsobom ako v prvom kroku.

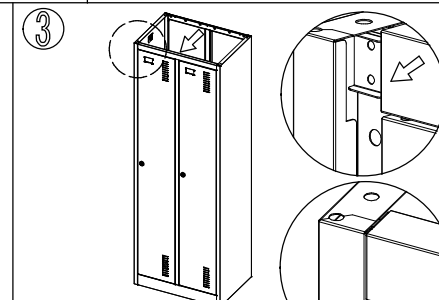

3 Pripevnite rám dverí na obe bočné dosky.

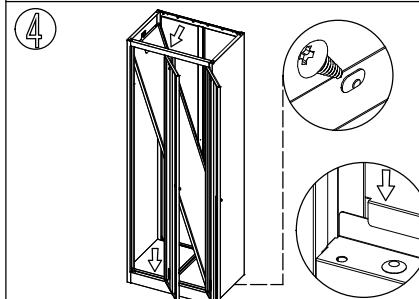

4 Nainštalujte spodnú dosku a potom upevnite deliacu dosku podľa označenia.

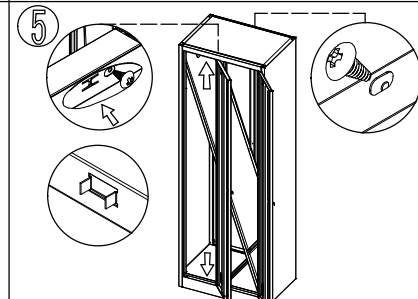

5 Nainštalujte vrchnú dosku a upevnite ju skrutkami (5x10).

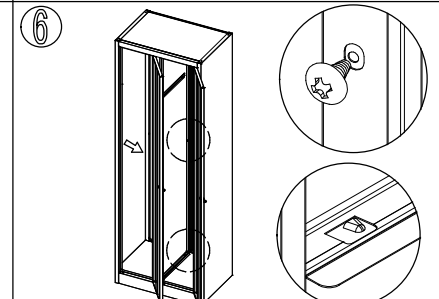

6 Nainštalujte deliacu dosku podľa označenia.

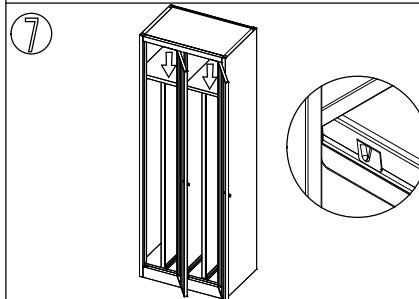

7 Pripevnite malé police podľa označenia a deliacej dosky.

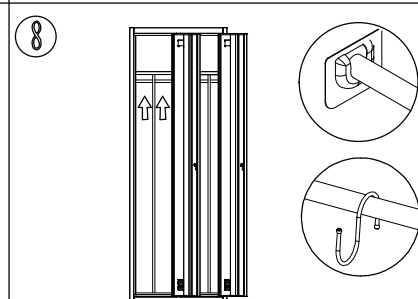

8 Nainštalujte vešiakovú tyč a háčiky.

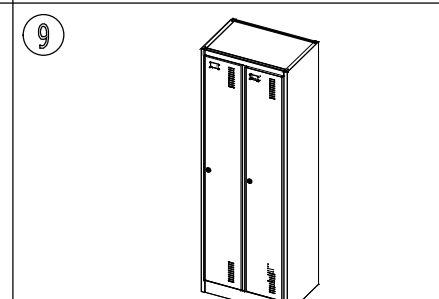

9 Po inštalácii upravte každú časť tak, aby dobre sedela.



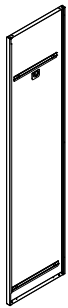

Levá strana: 1 ks



Pravá strana: 1 ks

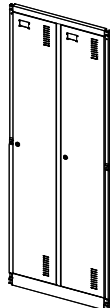

Rám dveří: 1 ks

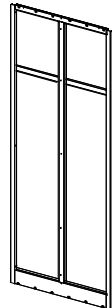

Zadní deska: 1 ks



Dělicí deska: 1 ks



Dělicí deska: 2 ks

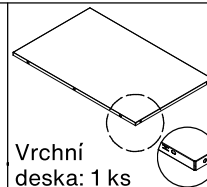

Vrchní deska: 1 ks

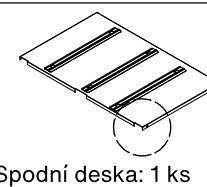

Spodní deska: 1 ks

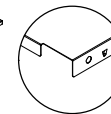

Malé police:
Levá (malá): 1 ks
Pravá (velká): 1 ks



Samořezné šrouby
(5x10): 19 ks



Klíče: 2 sady



Háčky: 8 ks

Věšáková tyč:
Krátká: 1 ks
Dlouhá: 1 ks
Střední: 2 ks

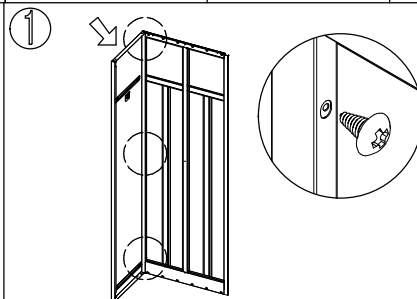
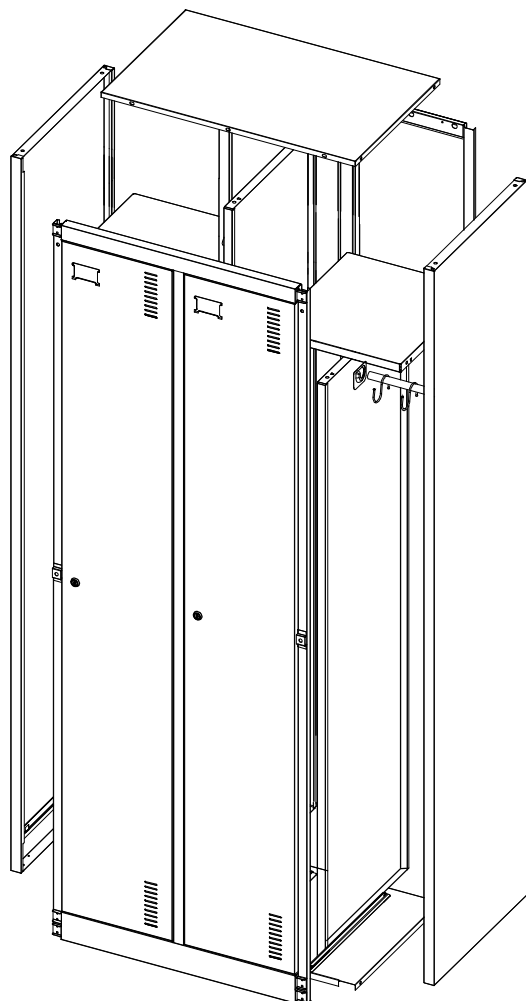
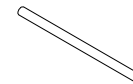

1 Přišroubujte levou stranu a zadní desku samořeznými šrouby (5x10).

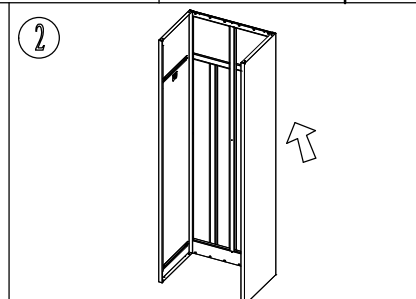

2 Pravou stranu přišroubujte k zadní desce stejným způsobem jako v prvním kroku.

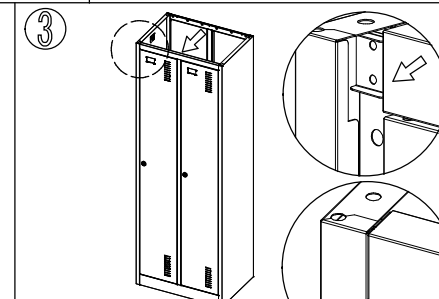

3 Připevněte rám dveří na obě boční desky.

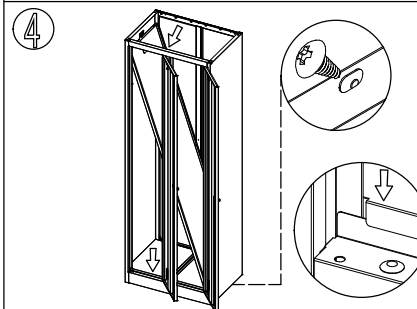

4 Nainstalujte spodní desku a poté upevněte dělicí desku podle označení.

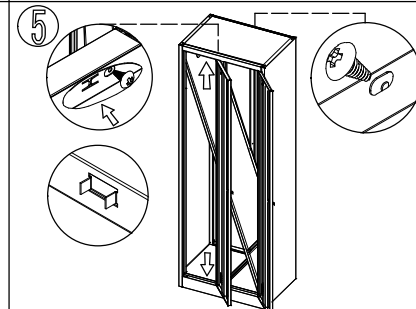

5 Nainstalujte vrchní desku a upevněte ji šrouby (5x10).

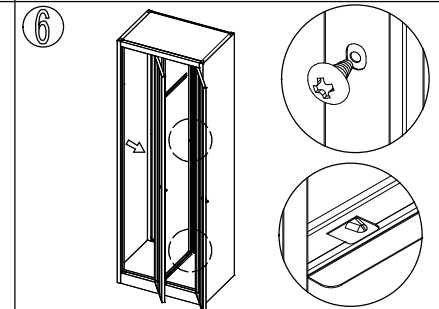

6 Nainstalujte dělicí desku podle označení.

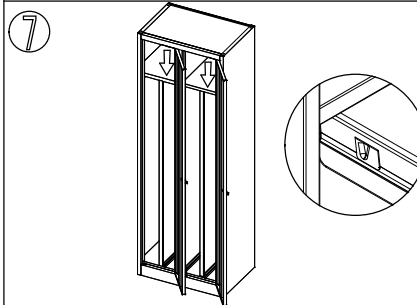

7 Připevněte malé police podle označení a dělicí desky.

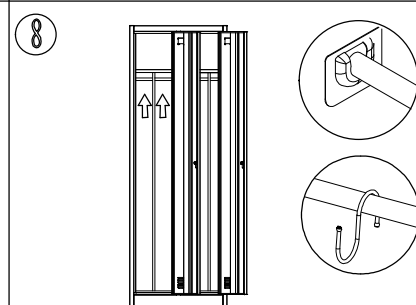

8 Nainstalujte věšákovou tyč a háčky.

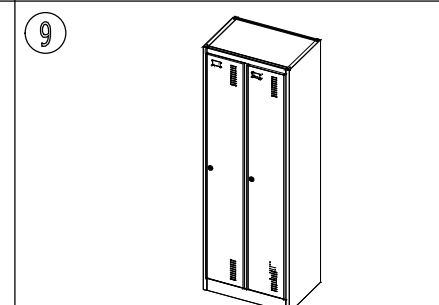

9 Po instalaci upravte každou část tak, aby dobře seděla.



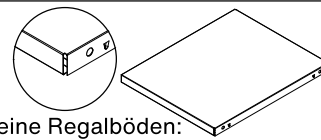
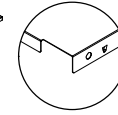
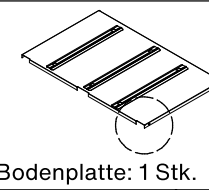
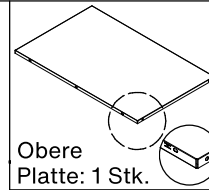
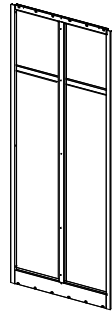
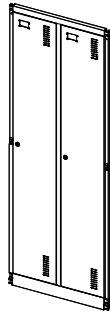
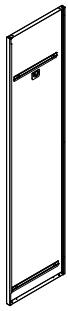

Obere
Platte: 1 Stk.

Bodenplatte: 1 Stk.

Kleine Regalböden:
Links (klein): 1 Stk.
Rechts (groß): 1 Stk.

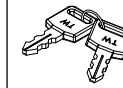

Selbstschneidende
Schrauben (5x10):
19 Stk.

Schlüssel: 2 Sets

Haken: 8 Stk.

Kleiderstange:
Kurz: 1 Stk.
Lang: 1 Stk.
Mittelgroß: 2 Stk.

Linke Seite: 1 Stk. Rechte Seite: 1 Stk. Türrahmen: 1 Stk. Rückwand: 1 Stk.

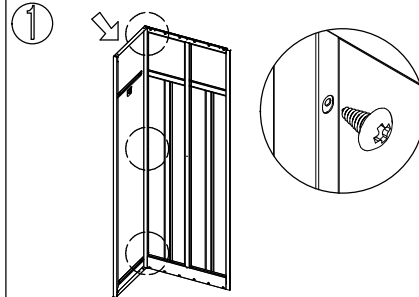

Schrauben Sie die linke Seite und die Rückwand mit selbstschneidenden Schrauben (5x10) zusammen.

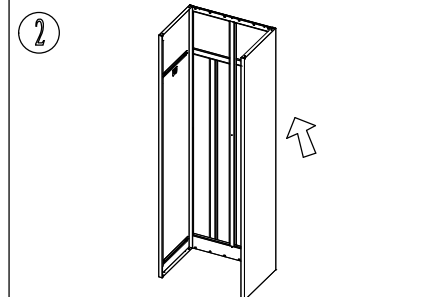

Befestigen Sie die rechte Seite auf die gleiche Weise wie im ersten Schritt an der Rückwand.

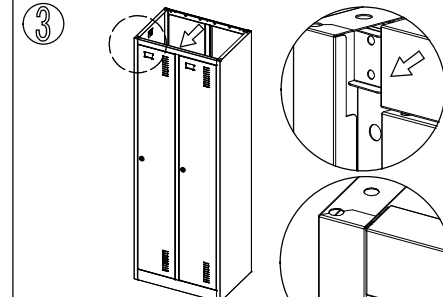

Befestigen Sie den Türrahmen an beiden Seitenplatten.

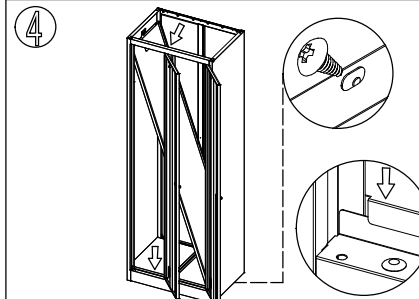

Montieren Sie die Bodenplatte und befestigen Sie anschließend die Trennplatte gemäß der Markierung.

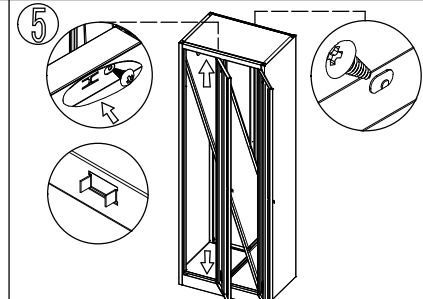

Montieren Sie die obere Platte und befestigen Sie sie mit Schrauben (5x10).

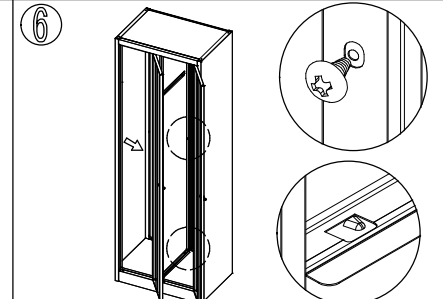

Montieren Sie die Trennplatte gemäß der Markierung.

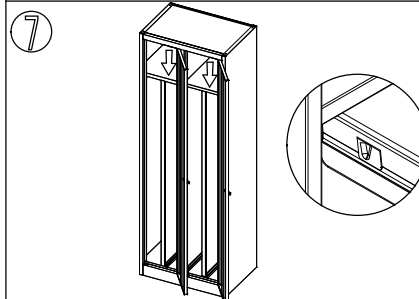

Befestigen Sie die kleinen Regalböden gemäß der Markierung und der Trennplatte.

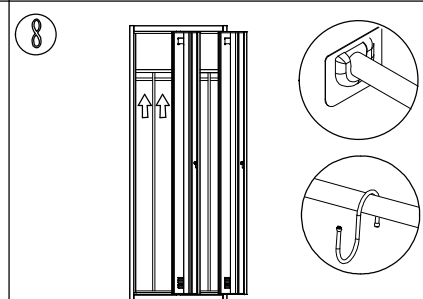

Montieren Sie die Kleiderstange und die Haken.

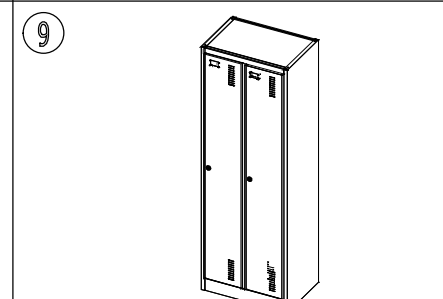

Richten Sie nach der Montage alle Teile so aus, dass sie gut sitzen.

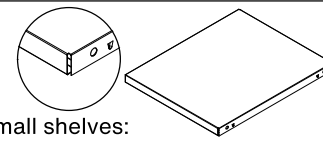
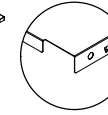
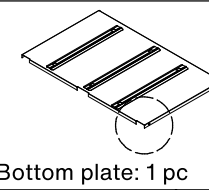
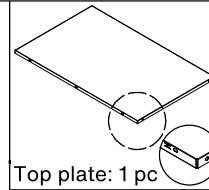
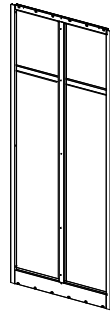
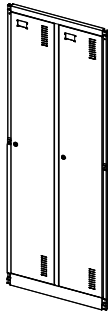
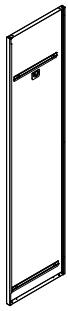

Small shelves:
Left (small): 1 pc
Right (big): 1 pc

Top plate: 1 pc

Bottom plate: 1 pc

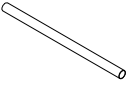
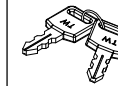

Self-tapping screw
(5x10): 19 pcs

Key: 2 sets

Hook: 8 pcs

Hanging rod:
Short size: 1 pc
Long size: 1 pc
The middle size: 2 pcs

Left side: 1 pc

Right side: 1 pc

Door frame: 1 pc

Back plate: 1 pc

Division plate: 1 pc

Division plate: 2 pcs

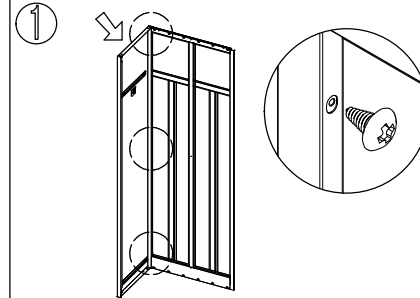
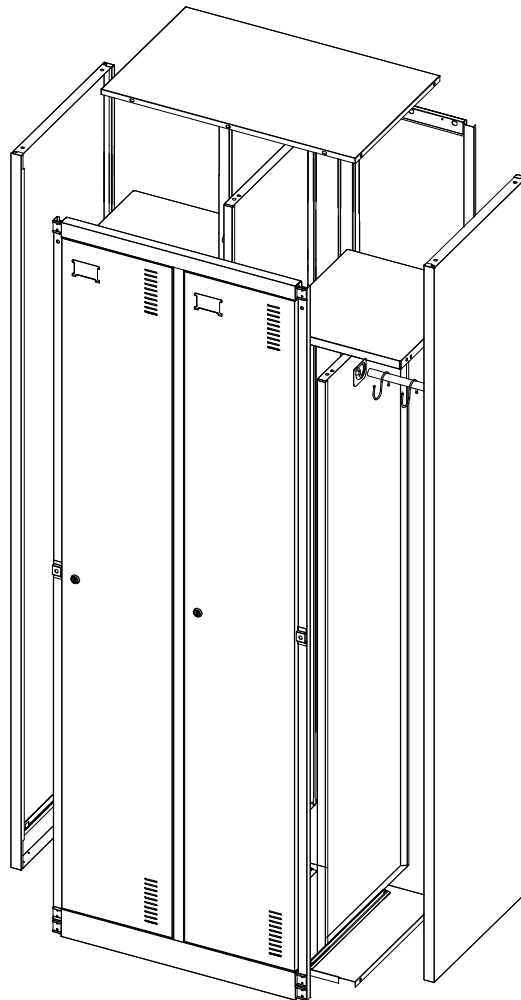

1 Bolt the left side and back plate with self-tapping screws (5x10).

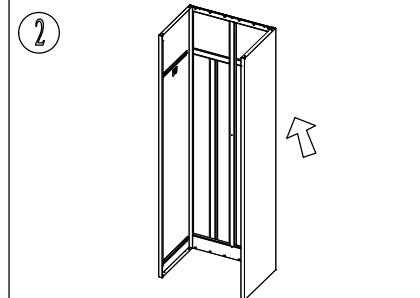

2 Bolt the right side with back plate in the same way as the first step.

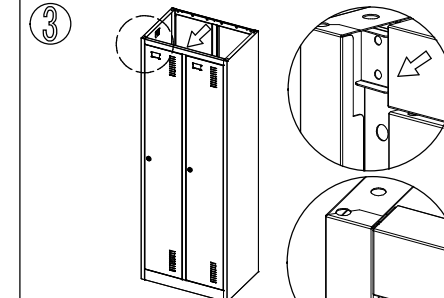

3 Fix the door frame onto both of the side plates.

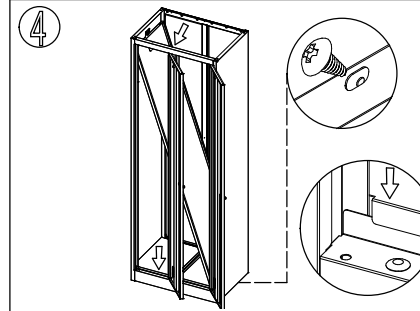

4 Install the bottom plate, then fix the division plate as the sign.

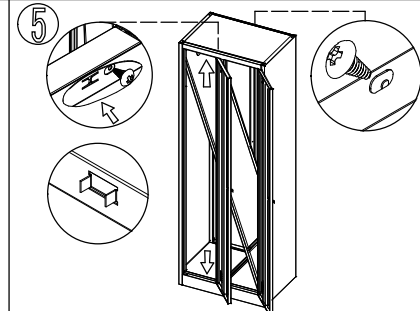

5 Install the top plate and fix with screws (5x10).

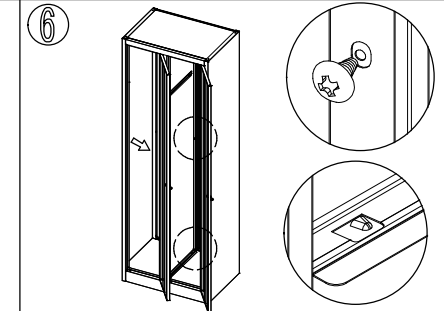

6 Install the divide plate as the sign.

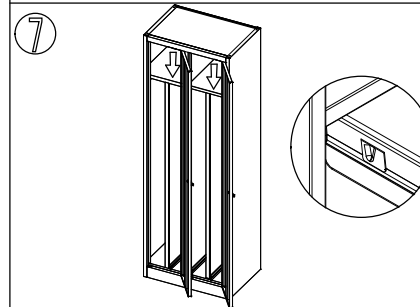

7 Fix the small shelves as the sign and the divide plate.

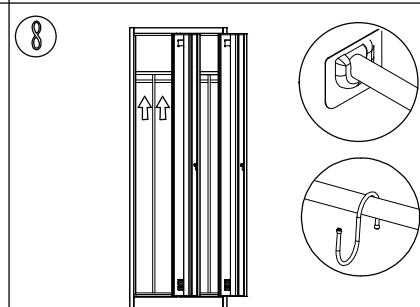

8 Install the hanging rod and hook.

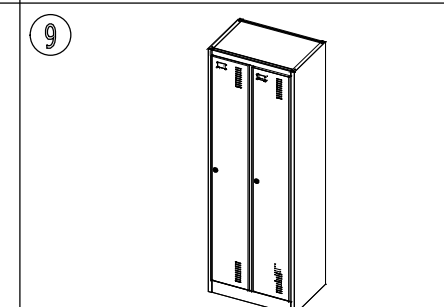

9 Adjust each part till fit well after installation.

ENG

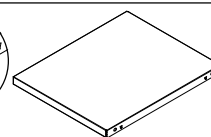
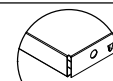
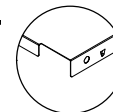
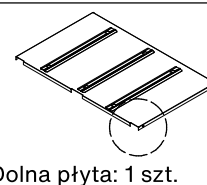
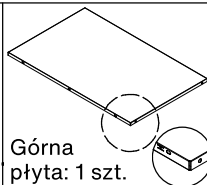
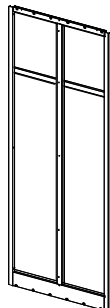
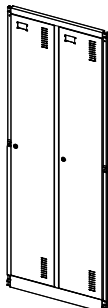
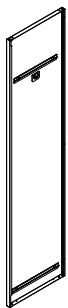

Lewa strona: 1 szt.

Prawa strona: 1 szt.

Rama drzwi: 1 szt.

Tylna płyta: 1 szt.

Płyta dzieląca: 1 szt.

Płyta dzieląca: 2 szt.

Górna płyta: 1 szt.

Dolna płyta: 1 szt.

Małe półki:
Lewa (mała): 1 szt.
Prawa (duża): 1 szt.

Wkręty samogwintujące (5x10): 19 szt.

Klucze: 2 zestawy

Haczyki: 8 szt.

Drażek do wieszania ubrań:
Krótki: 1 szt.
Długi: 1 szt.
Średni: 2 szt.

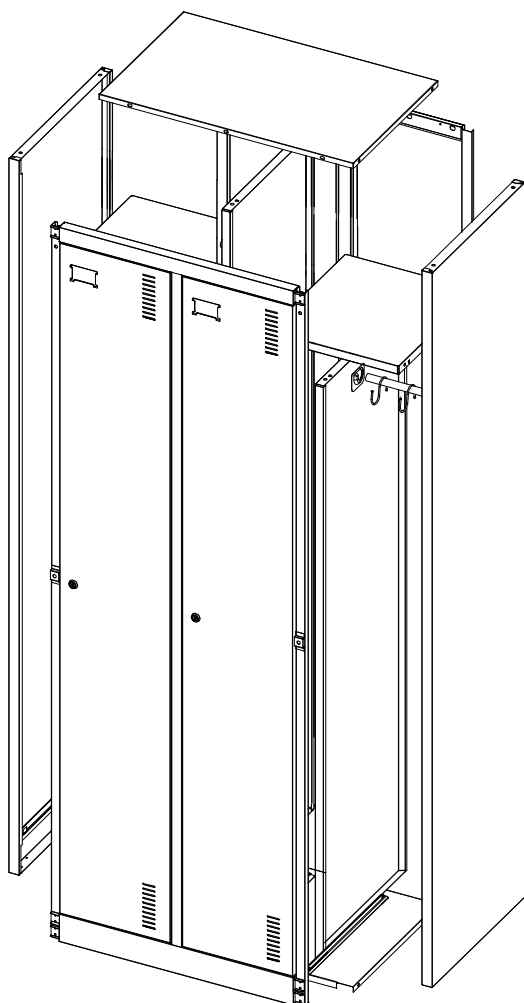

1

Przykręć lewą stronę i tylną płytę za pomocą wkrętów samogwintujących (5x10).

2

Przykręć prawą stronę do tylnej płyty w taki sam sposób jak w pierwszym kroku.

3

Przymocuj ramę drzwi do obu bocznych płyt.

4

Zamontuj dolną płytę, a następnie przymocuj płytę dzielącą zgodnie z oznaczeniem.

5

Zamontuj górną płytę i przymocuj ją śrubami (5x10).

6

Zamontuj płytę dzielącą zgodnie z oznaczeniem.

7

Przymocuj małe półki zgodnie z oznaczeniem i płytą dzielącą.

8

Zamontuj drążek do wieszania ubrań i haczyki.

9

Po montażu wyreguluj wszystkie części tak, aby dobrze pasowały.

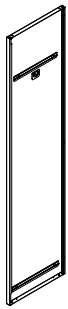

Partea stângă: 1 buc.



Partea dreaptă: 1 buc.

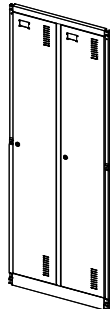

Rama ușii: 1 buc.

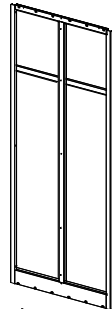

Panoul din spate: 1 buc.



Panou despărțitor: 1 buc.



Panou despărțitor: 2 buc.

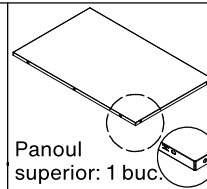

Panoul superior: 1 buc.

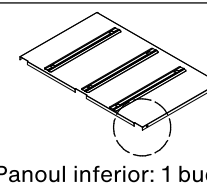

Panoul inferior: 1 buc.

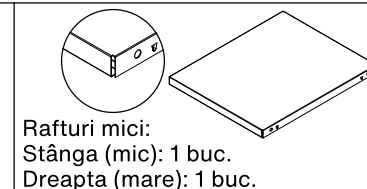
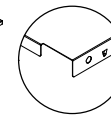

Rafturi mici:
Stânga (mic): 1 buc.
Dreapta (mare): 1 buc.



Șuruburi autofiletante (5x10): 19 buc.



Chei: 2 seturi



Cârlige: 8 buc.

Bară pentru agățarea hainelor:
Scurtă: 1 buc.
Lungă: 1 buc.
Medie: 2 buc.

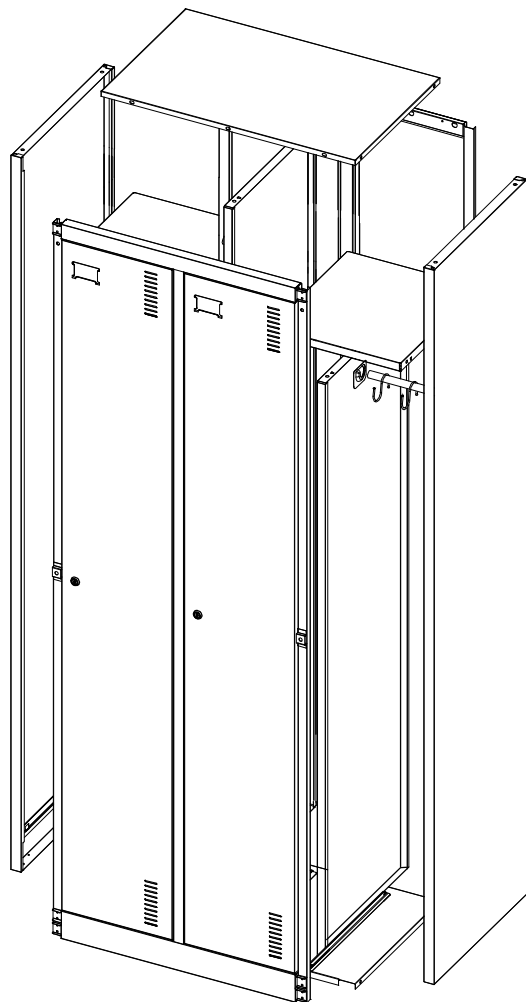
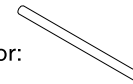

1

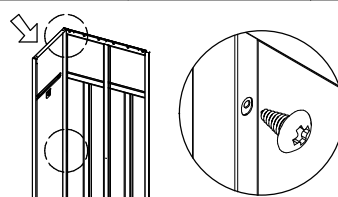

Înșurubați partea stângă și panoul din spate folosind șuruburi autofiletante (5x10).

2

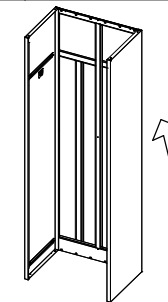

Fixați partea dreaptă de panoul din spate în același mod ca la primul pas.

3

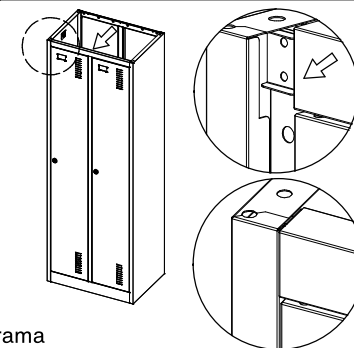

Fixați rama ușii pe ambele panouri laterale.

4

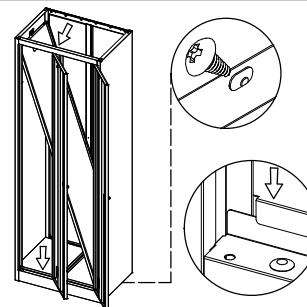

Instalați panoul inferior, apoi fixați panoul despărțitor conform marcăjului.

5

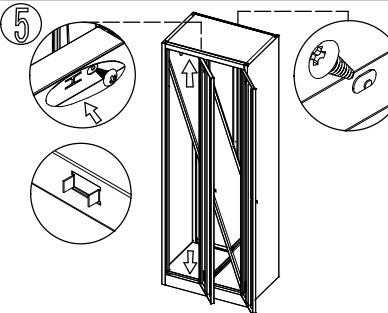

Instalați panoul superior și fixați-l cu șuruburi (5x10).

6

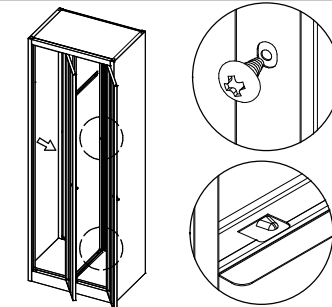

Instalați panoul despărțitor conform marcăjului.

7

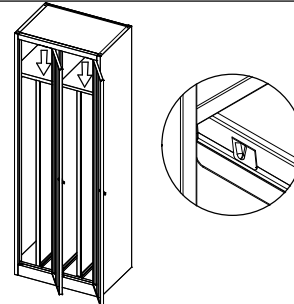

Fixați rafturile mici conform marcăjului și panoului despărțitor.

8

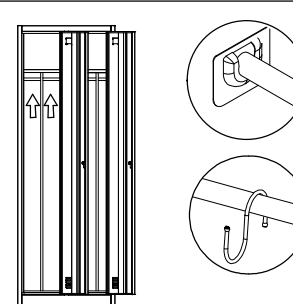





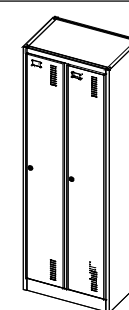

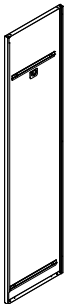

Instalați bara pentru haine și cârligele.

9

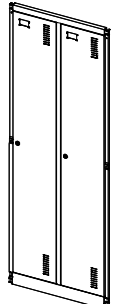
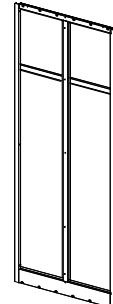
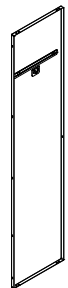

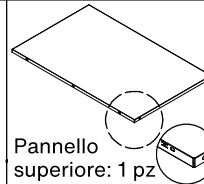
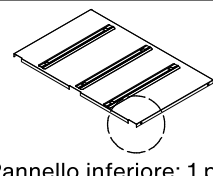
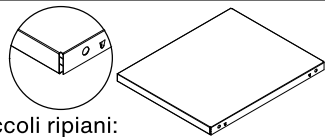
După instalare, ajustați fiecare parte astfel încât să se potrivească bine.

RO

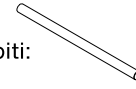
								
Lato sinistro: 1 pz	Lato destro: 1 pz	Telaio della porta: 1 pz	Pannello posteriore: 1 pz	Pannello divisorio: 1 pz	Pannello divisorio: 2 pz	Pannello superiore: 1 pz	Pannello inferiore: 1 pz	Piccoli ripiani: Sinistra (piccola): 1 pz Destra (grande): 1 pz
								
						Viti autofilettanti (5x10): 19 pz	Chiavi: 2 set	Ganci: 8 pz
								
								Barra appendiabiti: Corta: 1 pz Lunga: 1 pz Media: 2 pz

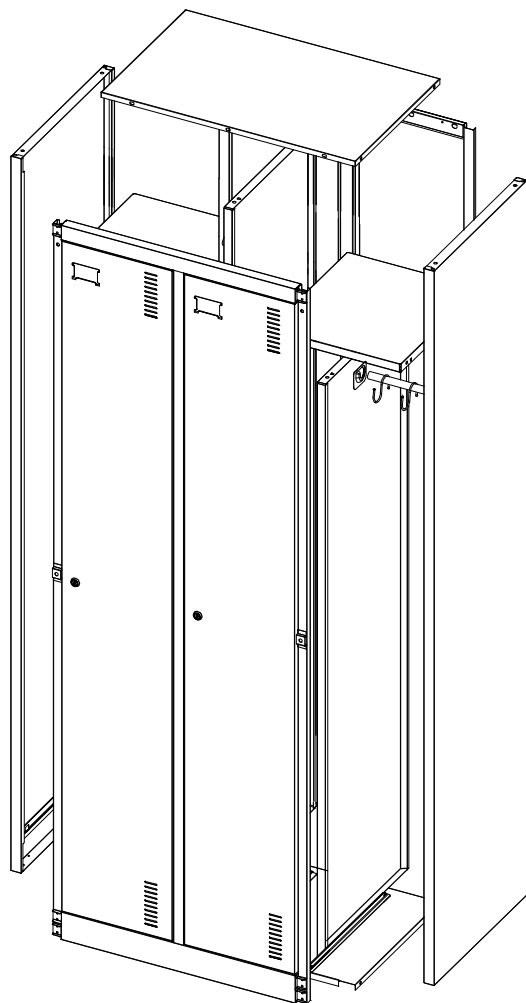

① 

Avvitare il lato sinistro e il pannello posteriore utilizzando viti autofilettanti (5x10).

② 

Fissare il lato destro al pannello posteriore nello stesso modo del primo passaggio.

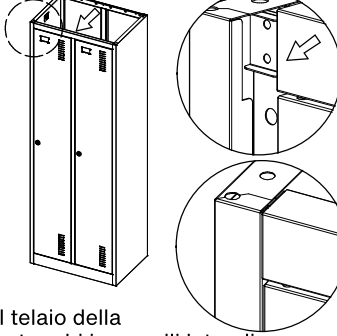
③ 

Fissare il telaio della porta a entrambi i pannelli laterali.

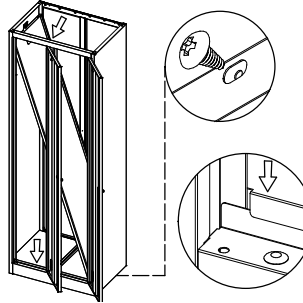
④ 

Installare il pannello inferiore e quindi fissare il pannello divisorio come indicato.

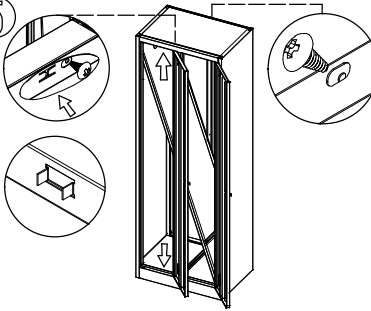
⑤ 

Installare il pannello superiore e fissarlo con viti (5x10).

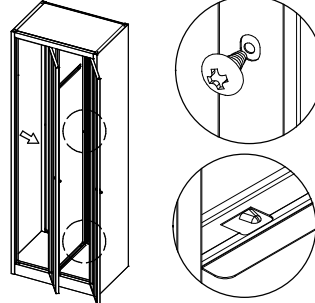
⑥ 

Installare il pannello divisorio come indicato.

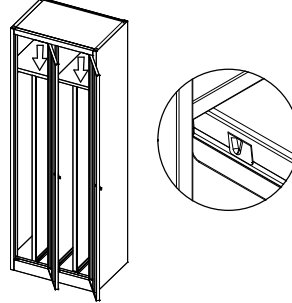
⑦ 

Fissare i piccoli ripiani come indicato e il pannello divisorio.

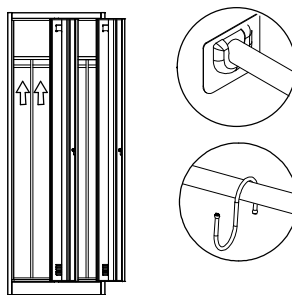
⑧ 

Installare la barra appendiabiti e i ganci.

⑨ 

Dopo l'installazione, regolare ogni parte in modo che si adatti correttamente.